



PSDM-55 Drum Mill

The Premier Mill PSDM-55 Drum Mill is an economical version of our popular PSM Submersible Basket Media Mill. This free-standing, stand mounted basket type mill has an independently powered milling shaft/basket assembly and a separate single mixing shaft. The PSDM Drum Mill is capable of processing mill batches from 20 to 55 gallons.

Ideal for industrial markets where inexpensive small batch coating dispersions are required. You will benefit from processing in 55-gallon drums, using Premier's *proven* Submersible Mill Technology.

Standard Features:

- Small batch submersible type basket media mill with maximum flexibility.
- Free-standing, no floor anchors: movable with forklift or pallet jack.
- Process small batches of 20 to 55 gallons (designed to fit into standard 55 gallon drum).
- For low viscosity batches up to 20,000 cps.
- RPM controlled with variable frequency drives.

Available Options:

304 Stainless steel screen assembly with various screen slots for different sized grinding beads. Select from the following:

- Screen slot opening 0.031" (0.787mm) for beads no less than 1.5mm (standard).
- Screen slot opening 0.024" (0.609mm) for beads no less than 1.0mm.
- Screen slot opening 0.016" (0.406mm) for beads no less than 0.8mm.

Benefits:

- Independent variable speed mixing action provides uniform dispersion and greater control over process variables (such as product temperature).
- Easy to clean for efficient production of small batches where with rapid color and formulation changeover is required.
- Low maintenance with few moving parts compared to traditional "continuous" media mills.

Applications:

- Pigment dispersions and color concentrates for Paint, Architectural and Industrial Coatings, Inks and Plastics.
- Pharmaceutical and Food Suspensions.
- Agricultural and Chemical Slurries.



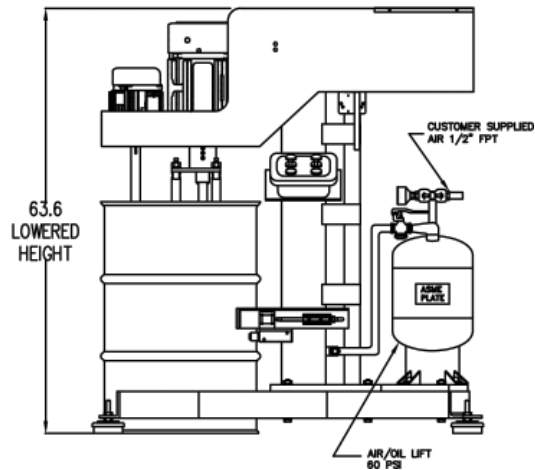
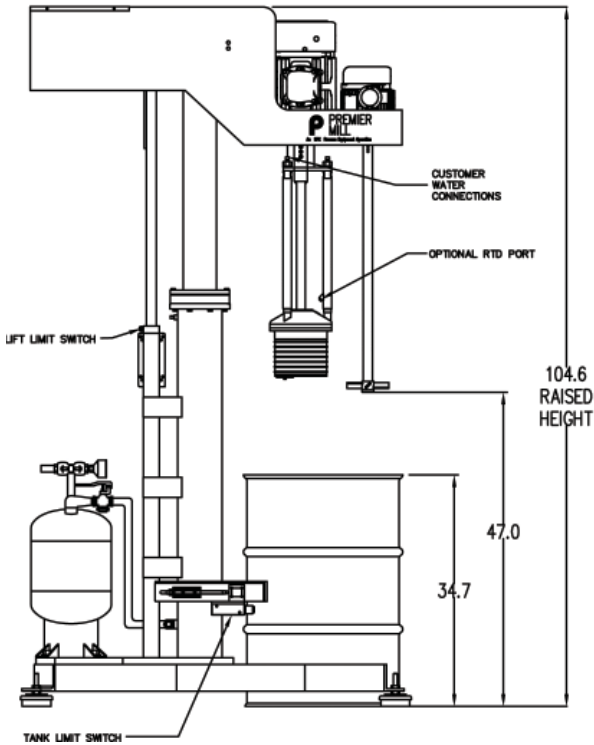
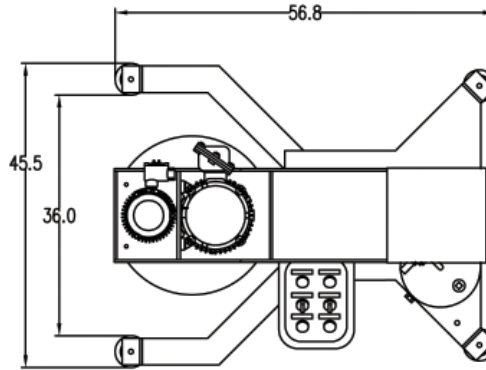
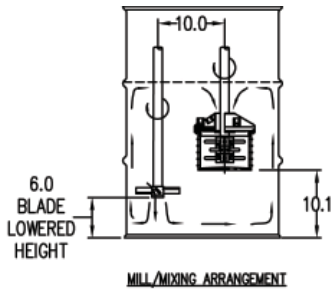

Dimensions are typical, subject to change.
Drum shown for demonstration purposes only.

SPX[®]
WHERE IDEAS MEET INDUSTRY

Your local contact:

Premier Mill, An SPX Brand
611 Sugar Creek Road, Delavan, WI 53115
Phone: (800) 252-5200 or (262) 728-1900, Fax: (262) 728-4904
E-mail: premiermill@spx.com

For more information about our worldwide locations, approvals, certifications, and local representatives, please visit www.premiermill.com.

SPX Corporation reserves the right to incorporate our latest design and material changes without notice or obligation. Design features, materials of construction and dimensional data, as described in this bulletin, are provided for your information only and should not be relied upon unless confirmed in writing.

Issued: 10/2009 PM-PSDM

Copyright © 2009 SPX Corporation