



# Premier Mill Universal Portable Mixer Stand

**Move Your Mixer, Not Your Tank! Portable Stand Mount** for various mixing applications, accepts high-speed to low-speed variable speed mixers and dispersers.

**Standard Features:**

- Portable stand with locking casters.
- Pneumatic lift cylinder.
- Three position control valve.
- Universal 304SS mounting plate, accepts up to 10 HP foot mounted motors.
- Pneumatic lift and portable stand relieves physical stress and strain on mixer operators.
- Manual craft lift for up to 5 HP (*UMS-M5*).

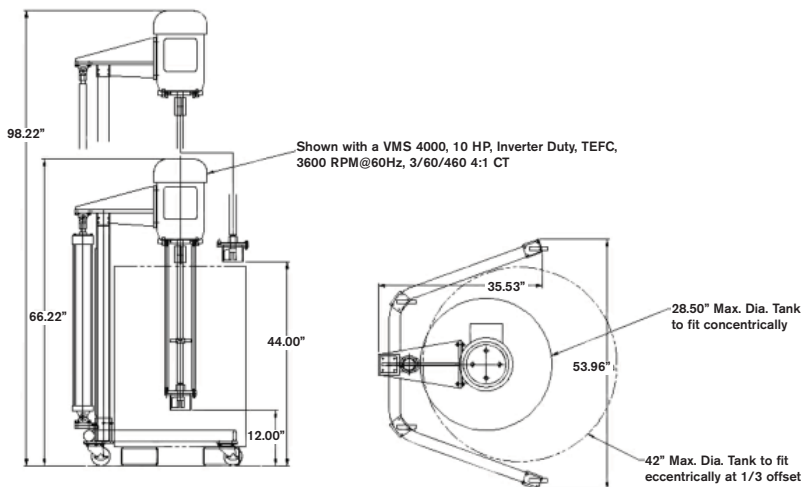

**Pneumatic  
Unit  
(UMS-P10)**

**Shown with a Premier  
Mill VMS 4000 Rotor  
Stator Mixer**

Premier Mill, An SPX Brand, 611 Sugar Creek Road, Delavan, WI 53115  
Phone: (800) 252-5200, Fax: (262) 728-4904  
E-mail: [premiermill@spx.com](mailto:premiermill@spx.com)

For more information about our worldwide locations, approvals, certifications, and local representatives, please visit [www.premiermill.com](http://www.premiermill.com).

SPX Corporation reserves the right to incorporate our latest design and material changes without notice or obligation.

Design features, materials of construction and dimensional data, as described in this bulletin, are provided for your information only and should not be relied upon unless confirmed in writing.

Issued: 10/2009 PM-USF

Copyright © 2009 SPX Corporation