



Vertical Max Shear Rotor/Stator Mixer

The Vertical Max Shear Rotor/Stator Mixer from Premier Mill - featuring a precision high-speed rotor, which creates a vigorous pumping action as it draws liquid into the stator inlet. Liquid is discharged at high velocity through machined slots in the stator. This results in a powerful combination of mechanical and hydraulic shear.

Certain processes such as emulsification of dispersing pigments and other solids particulate into a liquid medium require high shearing action. In many applications, Single Shaft Dispensers cannot achieve the desired results. Our Vertical Max Shear is the ideal solution. The Premier VMS Rotor/Stator Mixer produces: shorter mixing cycles, more uniform blending, faster wetting and dissolving of hard to wet powders, finer particle size of suspended solids, smaller emulsion droplet size and improved premixes to increase efficiency of down stream grinding devices (such as media mills).

Available for a wide range of processing industries, including: Personal Care, Adhesives and Sealants, Paint, Ink and Coatings, Chemical and Pharmaceuticals.

Standard Features:

- Close tolerance rotor/stator mechanism provides an effective combination of both "high flow" and "high shear".
- Large Rotor blade surface area and shearing edge for high pumping action and intensive mechanical shearing at the rotor/stator interface.
- Large internal Stator shearing surface area with fine slot openings for efficient homogenizing, emulsification, "grinding" and particle size reduction capability.
- All 316 stainless steel wetted components with Bronze shaft bearing as standard.

Available Options:

- Stators with Standard, Fine and Ultra-Fine Slot Openings.
- Down thrust Turbine Impellers for maximum product circulation.
- Sanitary construction with stainless steel motor housings for complete cleaning in place.
- Teflon shaft bearing (other materials available).

Capacity:

1 Liter (0.26 gallons) to
4,000 Liters (1,000 gallons)

Drive:

Direct Coupled - Operating at
standard industrial motor speeds

Horsepower:

3 HP to 30 HP

Variable Speed:

Optional by Electronic Variable
Frequency Drive

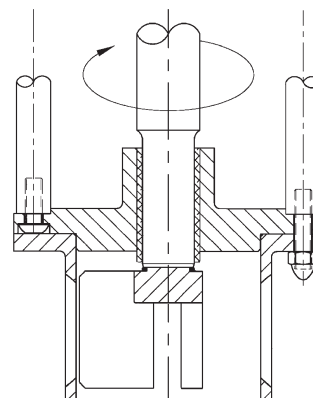

Side View

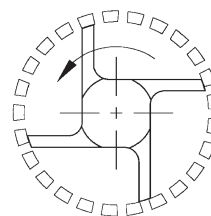

Suction View



VMS Rotor/Stator Mixer						
Model Number	HP/Speed	Capacity/Gallons	Rotor/Dia. (Inches) "A"	Depth Dim. (Inches) "B"	Approx. Height (Inches) "C"	Approx. Weight (Pounds)
VMS3000-3	3.0/1800	50	3.00"	32"	56"	225
VMS3000-5	5.0/3600	100	3.00"	32"	56"	225
VMS4000-5	5.0/1800	100	4.00"	36"	60"	240
VMS4000-10	10/3600	200	4.00"	36"	60"	275
VMS4000-15	15/1800	500	5.85"	48"	76"	610
VMS8000-30	30/1800	1000	7.75"	60"	88"	670

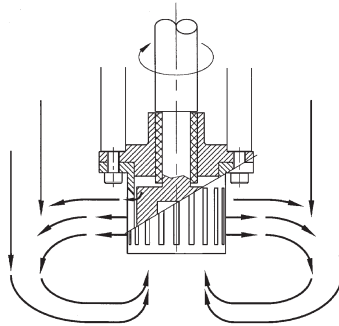
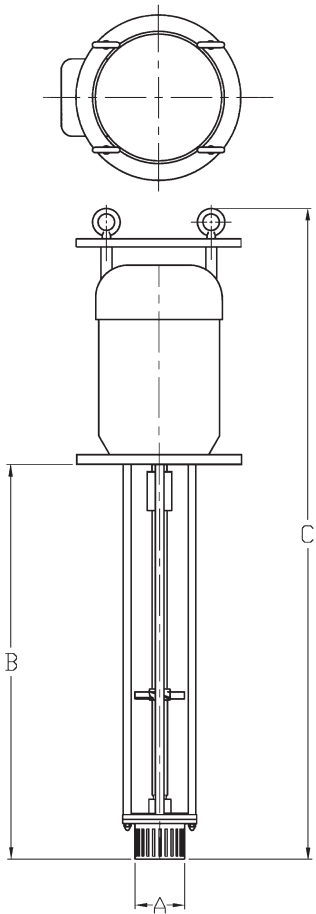

Flow Pattern of VMS



Disperser/Emulsifier - Reduces Mixing Times With Consistent, Repeatable Results



Your local contact:



Premier Mill, An SPX Brand
 611 Sugar Creek Road, Delavan, WI 53115
 Phone: (800) 252-5200 or (262) 728-1900, Fax: (262) 728-4904
 E-mail: premiermill@spx.com

For more information about our worldwide locations, approvals, certifications, and local representatives, please visit www.premiermill.com.

SPX Corporation reserves the right to incorporate our latest design and material changes without notice or obligation. Design features, materials of construction and dimensional data, as described in this bulletin, are provided for your information only and should not be relied upon unless confirmed in writing.